

Condition

explain quantum in time sharing OS.

Answer

A **time sharing system** allows many users to share the computer resources simultaneously. In other words, time sharing refers to the allocation of computer resources in time slots to several programs simultaneously. For example a mainframe computer that has many users logged on to it. Each user uses the resources of the mainframe -i.e. memory, CPU etc. The users feel that they are exclusive user of the CPU, even though this is not possible with one CPU i.e. shared among different users.

The time sharing systems were developed to provide an interactive use of the computer system. A time shared system uses CPU scheduling and multiprogramming to provide each user with a small portion of a time-shared computer. It allows many users to share the computer resources simultaneously. As the system switches rapidly from one user to the other, a short time slot is given to each user for their executions.

The time sharing system provides the direct access to a large number of users where CPU time is divided among all the users on scheduled basis. The OS allocates a set of time to each user. When this time is expired, it passes control to the next user on the system. The time allowed is extremely small and the users are given the impression that they each have their own CPU and they are the sole owner of the CPU. This short period of time during that a user gets attention of the CPU is known as a **time slice or a quantum**. The concept of time sharing system is shown in figure.

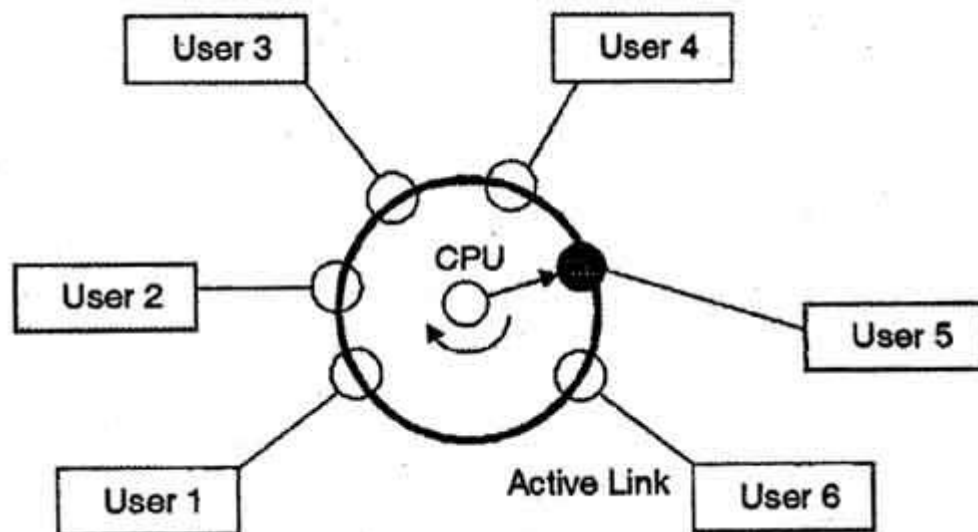

In above figure the user 5 is active but user 1, user 2, user 3, and user 4 are in waiting state whereas user 6 is in ready status.

As soon as the time slice of user 5 is completed, the control moves on to the next ready user i.e. user 6. In this state user 2, user 3, user 4, and user 5 are in waiting state and user 1 is in ready state. The process continues in the same way and so on.

The time-shared systems are more complex than the multi-programming systems. In time-shared systems multiple processes are managed simultaneously which requires an adequate management of main memory so that the processes can be swapped in or swapped out within a short time.

Note: The term 'Time Sharing' is no longer commonly used, it has been replaced by 'Multitasking System'.