

Answer on Question #40808, Physics, Mechanics

A 15 kg block rests on the surface of a plane inclined at an of 30 degrees to the horizontal. A light inextensible string passing over a small, smooth pulley at the top of the plane connects the block to another 13 kg block hanging freely. The coefficient of kinetic friction between the 15 kg block and the plane is 0.25. Find the acceleration of the blocks.

Solution:

Given:

$$m = 15 \text{ kg,}$$

$$M = 13 \text{ kg,}$$

$$\theta = 30^\circ,$$

$$\mu_k = 0.25$$

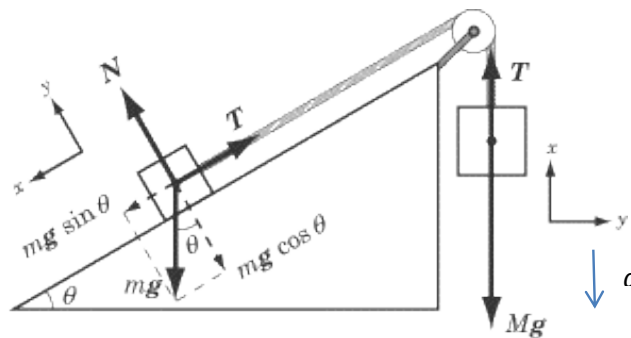

First, let's determine the net force acting on each of the masses. Applying Newton's Second Law we get:

$$\text{for mass } M: Mg - T = Ma$$

$$\text{for mass } m: T - mg \sin \theta - \mu_k N = ma$$

Adding these two equations together, we find that

$$Mg - T + T - mg \sin \theta - \mu_k N = Ma + ma$$

$$Mg - mg \sin \theta - \mu_k N = a(M + m)$$

The friction force

$$\mu_k N = \mu_k mg \cos \theta$$

Thus,

$$a = \frac{g(M - m \sin \theta - \mu_k m \cos \theta)}{(M + m)}$$
$$a = \frac{9.81 \cdot (13 - 15 \cdot \sin 30^\circ - 0.25 \cdot 15 \cdot \cos 30^\circ)}{(13 + 15)} = 0.7891 \approx 0.79 \text{ m/s}^2$$

Answer. $a = 0.79 \text{ m/s}^2$.